

electric
smart
powerful

Generation 6 Mobile Harbor Cranes



The DNA for the crane of the future

Meeting tomorrow's cargo handling requirements today: This is the essence of Konecranes Gottwald Mobile Harbor Cranes – and has been for more than 60 years. Innovation is our tradition, based on our experience as the inventor of the mobile harbor crane. Developments are always oriented towards market requirements and customer needs. Our Generation 6 mobile harbor cranes set the standard in response to market-relevant megatrends. They are specially tailored to the port industry of the future: Modular and of innovative design, they impress with

smart functions for automation and connectivity, for example, as well as with high performance and availability. With their energy-efficient drive systems, proven robustness and reliability as well as high ease of maintenance, our cranes combine cost-effectiveness with eco-efficiency. Our crane DNA is based on the sustainable success formula "electric - smart - powerful." This means that our powerful cargo-handling cranes are equipped to meet all challenges. Not only today, but in the future, too.

ELECTRIC

PAGES 8-12

Clean drive solutions for sustainable cargo handling

SMART

PAGES 14-20

Smart working environment thanks to connectivity, ergonomics and operator assistance systems

POWERFUL

PAGES 22-26

Robust design combined with intelligence for maximum availability and performance



For all types of terminals, applications and vessel sizes

Generation 6 portfolio

With the launch of Generation 6, we are presenting our six mobile harbor crane models. As true all-rounders, they can, for example, serve vessels including super post-Panamax class in container handling, and vessels including Capesize class in bulk handling. In general

cargo and project cargo handling, they impress with their powerful lifting capacity curves and a lifting capacity of up to 200 t (400 t in tandem lift with two cranes).

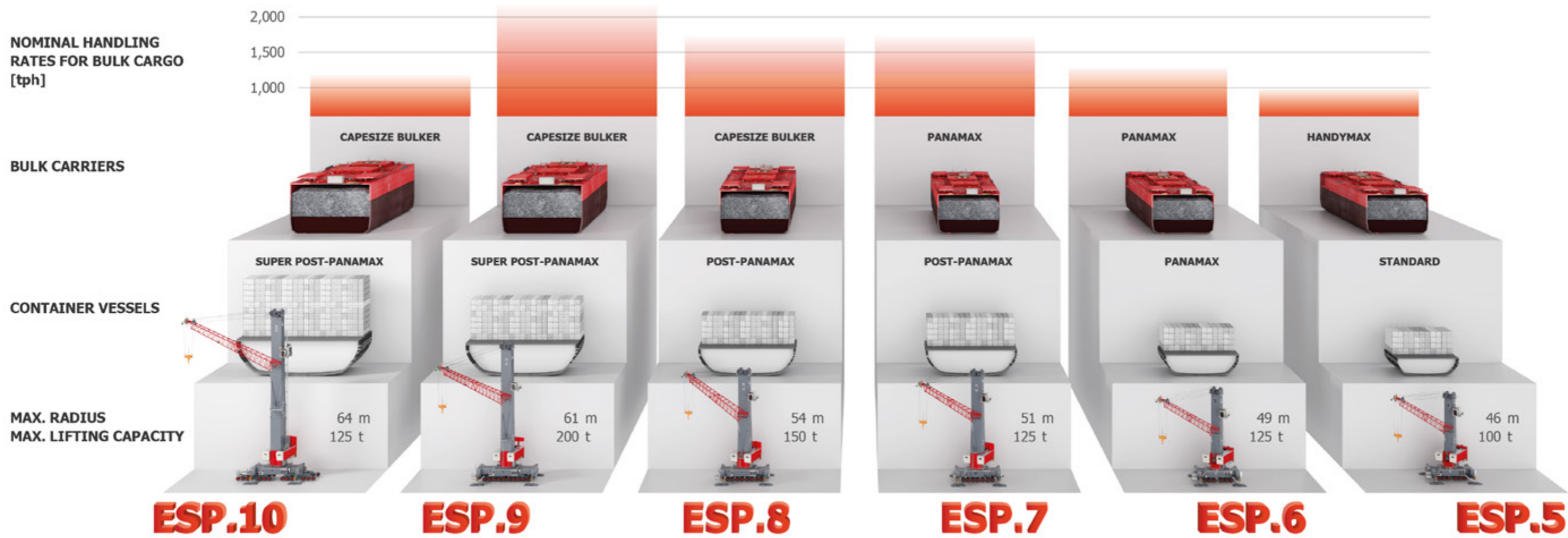
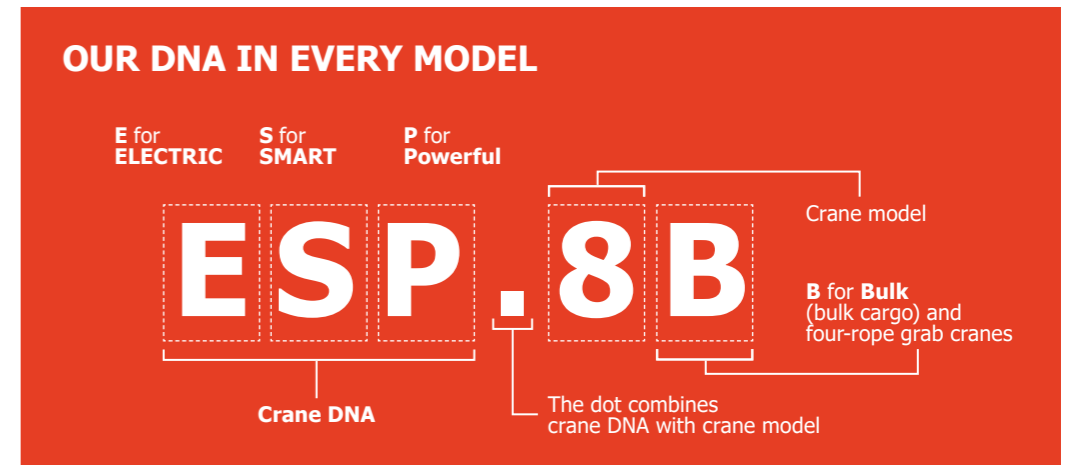

COMBINED WITH

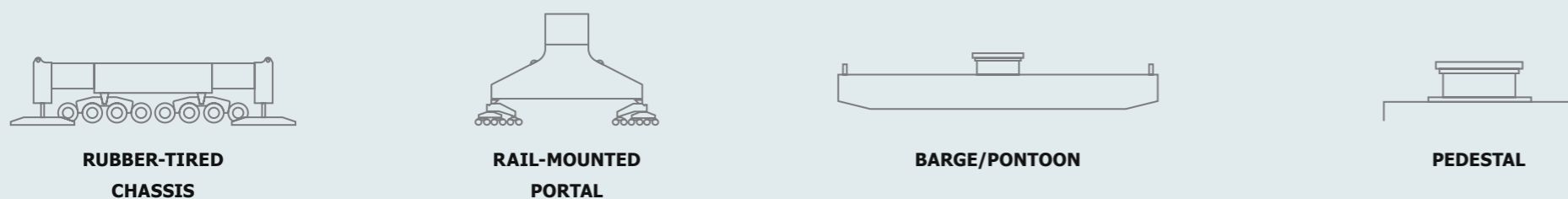

OUR MODULAR MOBILE HARBOR CRANES FOR ALL TYPES OF TERMINALS

Adapted to their respective working environment, they are available as mobile harbor cranes on rubber-tired chassis, as portal harbor cranes on rail-mounted portals, as cranes on barges or pontoons or as pedestal-mounted cranes mounted directly at the terminal. Terminal operators worldwide profit from these versatile crane types.

Combination of proven and innovative

Generation 6 design principle

For decades, the secret of success of Konecranes Gottwald Mobile Harbor Cranes has been the combination of proven design solutions and innovative developments.

We work closely with our customers to meet current and future market requirements using state-of-the-art technologies. The result of this development is high-performance cargo-handling cranes that successfully combine economy and ecology.

With Konecranes Gottwald Mobile Harbor Cranes, terminal operators benefit from a high degree of flexibility in adapting the crane to a specific application. Our experts advise on planning – personally and digitally, including with our innovative, multimedia crane configurator (see page 27).

INTEGRATED CONCEPT

Konecranes Gottwald Generation 6 Mobile Harbor Cranes are characterized by an holistic design concept. This is how we create a high added value for operators. The modular design is well-conceived down to the last detail, from the crane's steel construction to its software, and includes many innovative features and performance-matched functionality.

This ensures a high degree of flexibility in the technical equipment of the cranes – providing high availability and ease of maintenance, which is reflected in maximum reliability across all crane models.

HOIST

- Hoist gear units with three-phase drive for increased efficiency, speed and acceleration
- Proven two- and four-rope hoist designs for high-performance handling of all types of cargo

SUPERSTRUCTURE

- Familiar, spacious room concept for high ease of maintenance
- Better access to components inside and outside the superstructure
- Innovative ventilation system for fresh air supply to all components

ALL-ROUND SAFE AND SECURE ACCESS

- 360° access in every superstructure position, and walkways secured by railings

CHASSIS

- Compact H-shaped stabilizer arrangement for maximum stability
- Robust, proven travel gear that enables small turning radii and crab steering for optimum maneuverability on any terrain

POWER SUPPLY

- Generously dimensioned cable reel for the external power supply
- Battery-powered drive for electrical mobility without diesel engine
- Standardized 625 kW diesel engines across the entire product range
- Hybrid drive – combination of diesel engines with 125 kW ultracaps

Red colored areas are used to identify technical and structural components – image includes optional components

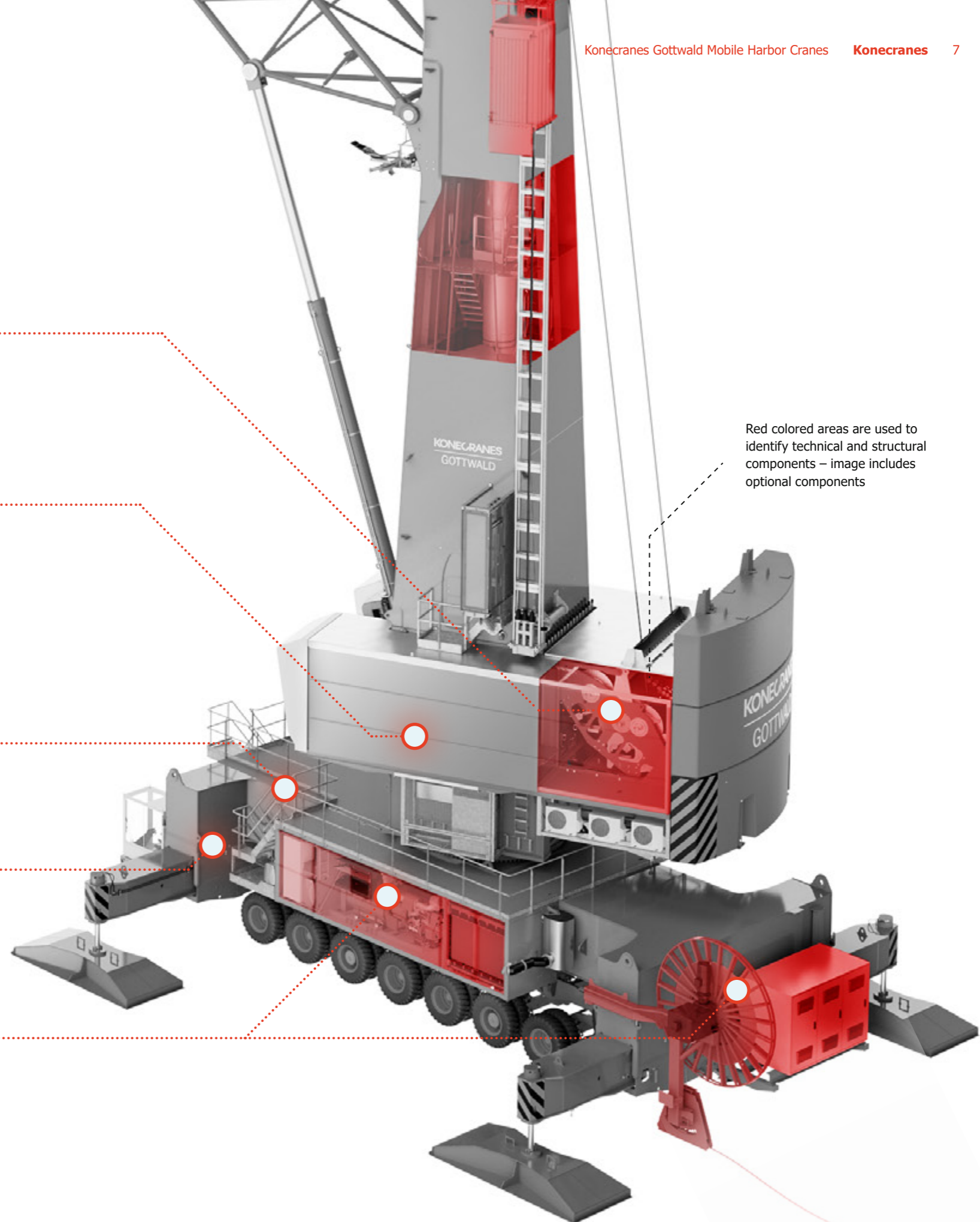

Designed for enhanced ergonomics

Focus on convenience and efficiency

Generation 6 mobile harbor cranes impress not only with their proven performance, but also with their high ease of maintenance and enhanced ergonomics. Ample space and free access to all maintenance points facilitate service work. For easy and thus efficient operation,

we design our cranes with ergonomic stairways and a comfortable and convenient workplace with excellent view of the working environment, and innovative features.

BOOM

- Proven three-chord lattice design for high boom stability and exact load positioning
- Maintenance-free LED headlights for excellent illumination of the working environment

TOWER

- Robust, closed steel structure with internal, ergonomically designed stairs to protect against adverse weather conditions
- Efficient ventilation: Fresh air supply to all consumers by means of air intake above the tower cab and forwarding via an internal pipe; can be equipped with an additional filter system
- Maintenance platforms at the boom pivot point and additionally on the outside of the tower for service work
- Elevator solutions for all models on the outside of the tower as a second full access point

TOWER CAB

- Designed for ergonomics and convenience
- Enlarged glass surfaces and an additional floor window allow the best view of the working environment
- Completely redesigned interior in dark design to reduce reflection effects and with plenty of storage space for safety equipment and personal items
- Modern crane management system and expandable digital camera system, visualized on a large work monitor

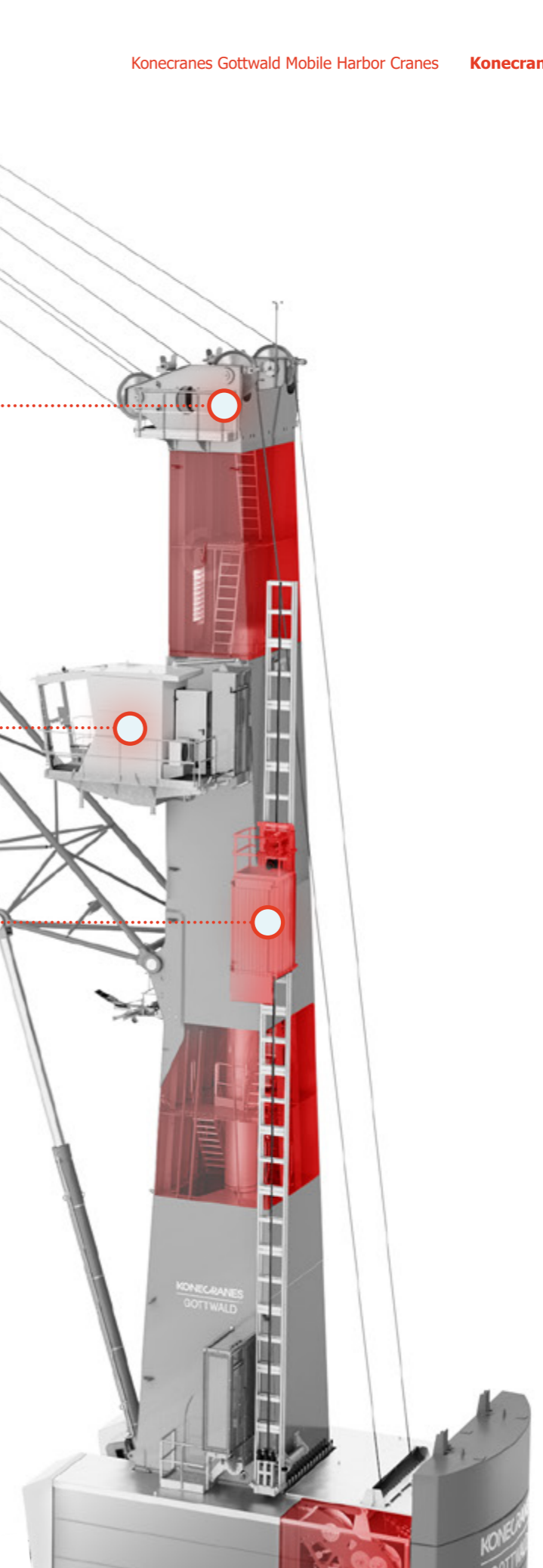
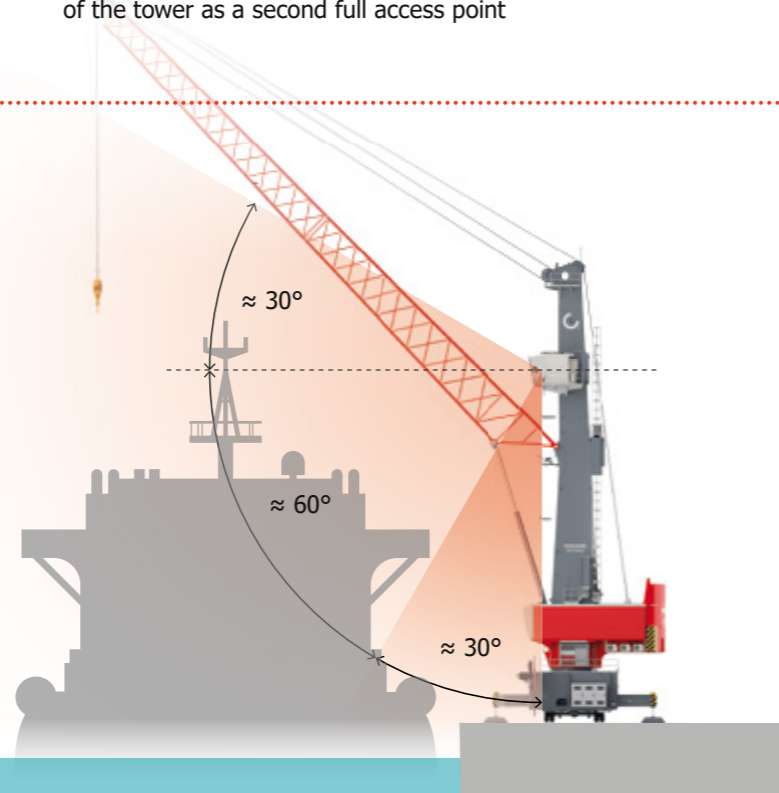

E for Electric

Konecranes Gottwald Mobile Harbor Cranes have impressed with their electric drive concept for many years. This proven characteristic component has been innovatively enhanced and enables efficient crane operation. It is the foundation for cost-effective, efficient and environmentally friendly use. This is a major competitive factor for the port industry of the future.

Our Generation 6 is designed to use external power sources as well as to operate independently of the grid with consumption-optimized diesel-generator sets and modern hybrid drives. Renewable energies such as wind and solar power from the on-shore grid enable continuous zero-emission operation. This concept is part of our "Powered by Ecolifting" vision: Minimizing emissions while improving productivity.

DECARBONIZATION

Our new crane generation helps to reduce the CO₂ emissions of terminals. Thanks to its state-of-the-art energy concepts, the new generation supports the switch to eco-friendly types of drives and thus meets stringent environmental requirements. It enables sustainable operation and is helping to drive the switch to renewable energy sources in the port industry.

SUSTAINABILITY

Electrical drive technology is one of our core competences. With Generation 6, we are offering a completely new electrical solution – thanks to the combination of external power sources and battery-powered operation. By dispensing with combustion engines here, we reduce energy and maintenance costs. In terminals where no external power source is available, we offer energy-efficient hybrid drives with consumption-optimized diesel-generator sets.

ECO-EFFICIENCY

When developing Generation 6, we focused particularly on eco-efficiency to reduce emissions in ports and terminals. Our new cranes stand for high-speed cargo handling with maximum energy efficiency. All our models combine productivity and performance with reduced energy consumption.

ELECTRIC DRIVE

More on pages 12 and 13

ON-BOARD SOLUTIONS

More on pages 14 and 15

Well-equipped for the future

Innovative drive system – for greater efficiency

We are continuing the success story of the electric drive concept for mobile harbor cranes with our newly developed drive system. Terminal operators benefit from the use of a future-proof technology that is ecologically and economically sustainable. Service managers appreciate the ease of maintenance and reduced downtimes thanks to longer maintenance intervals compared to other drive types. Crane operators achieve maximum handling performance thanks to energy-to-performance matched movements and high rates of acceleration of the drive system.

PRACTICAL SUPPLY FROM EXTERNAL POWER SOURCES

More and more ports are opting to use external energy sources. Demand for state-of-the-art cargo-handling cranes, with the ability to use external power sources, is growing steadily. With Generation 6, we are responding with a systematic answer: the new modular drive concept offers maximum flexibility in the use of external power sources of different voltages – right from the start or easily retrofitted at a later date. In addition, all cranes have efficient frequency controlled three-phase drives for efficient and power-optimized crane motions with negligible grid reactions when using external power sources.

NEW: BATTERY AS AN ALTERNATIVE CLEAN POWER SOURCE

External power sources are already used in numerous terminals. On-board diesel-generator sets are used as an alternative power source to move the crane or to operate it independently of the grid. With Generation 6, we are now offering a world first: Mobile harbor cranes with highly efficient battery-powered operation as an power source. Lithium-ion technology, already proven in other Konecranes products, provides the necessary energy to move cranes between different locations and for the extension and retraction of the propping system stabilizers. All crane motions can also be used for a short time.

This concept significantly reduces noise and exhaust emissions from the cargo-handling cranes. If the external power also comes from renewable sources, our cranes use an emission-free energy chain.

NEW AND UNIQUE TO MOBILE HARBOR CRANES: BATTERY-POWERED DRIVE

Konecranes offers a battery-powered drive as an alternative power source for its Generation 6 mobile harbor cranes. This allows operators to move and prop the crane, and to perform crane motions independently of external power sources.

REGENERATIVE, EMISSION-FREE ENERGY CHAIN

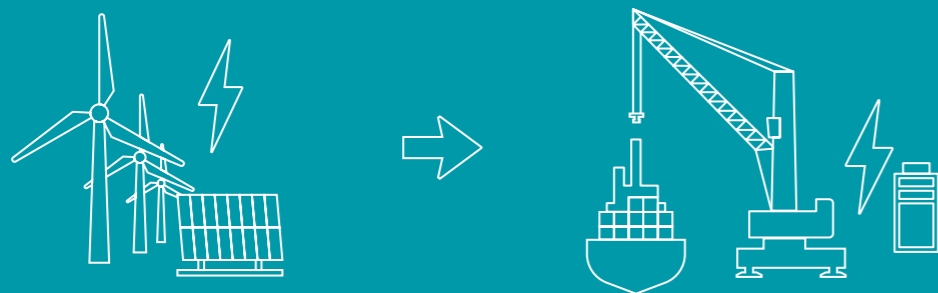

Independent and flexible – our modular drive system

Proven on-board solutions

Konecranes Gottwald Mobile Harbor Cranes provide grid-independent operation via proven on-board solutions consisting of consumption-optimized diesel-generator sets and electrostatic capacitors. The modular drive system can be individually configured according to requirements.

radiator and, if required, SCR system (selective catalytic reduction), is installed in a separate container to save space. The container is mounted on the side of the chassis – for solutions with two diesel engines on both sides. For service purposes, the containers can be quickly dismantled and transported by forklift truck.

ONE ENGINE TYPE FOR ALL

We use a 6-cylinder diesel engine with a primary output of 625 kW for all models. This concept offers our customers high spare parts availability from the manufacturer's global service network. The engines comply with the current EPA Tier 4f emissions regulations and EU Stage V if equipped with efficient after-treatment of exhaust gases. Depending on the crane size, application and required power, two synchronized motors can also be used. The complete diesel-generator set, consisting of engine, generator,

HYBRID DRIVES

The diesel-generator sets can be expanded on modular basis with high-performance capacitors (ultracaps) as an innovative energy storage solution. The individual electrostatic capacitors provide an additional power of 125 kW each if required. For the optimal interaction of ultracaps and engine, we have once again specifically further developed this system, which has been proven over many years, with regard to energy management and control systems. Ultracaps can be retrofitted to all models at any time.

THE MODULAR ON-BOARD DRIVE SYSTEM

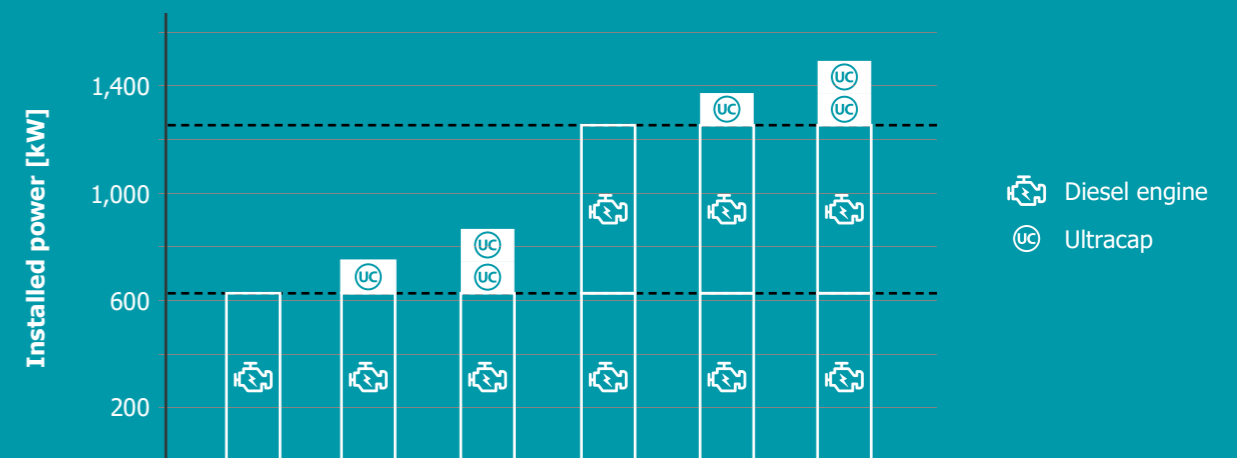

S for Smart

With the combination of intelligence and machine, we offer our customers smart, high-performance and reliable cargo-handling cranes. Generation 6 stands for efficient operation at all times and an ergonomic working environment. The focus is on safety and convenience with the aim of achieving the highest possible performance yield. A newly designed tower cab with generous window areas for the best view of the working area and innovative operating concepts improves the working environment of the crane operators and thus their productivity. Our proven and enhanced smart crane features support many work processes. The digital interconnectivity of our cranes provides our customers with a high level of transparency regarding the technical condition of the equipment and the handling achieved.

I AUTOMATION

Automated processes increase productivity in terminals. Higher handling rates, less resource-demanding, scalability and increase reliability are benefits of the smart crane features of the new crane generation.

I DIGITALIZATION

Our Generation 6 cranes have connectivity through digital interfaces and sensor technology. The interconnectivity of the cranes supports the analysis of crane data as well as processes, and supports service work via remote access. In doing so, cyber security and data protection are our top priorities.

I ERGONOMICS

We have always placed the highest demands on the productivity of our cranes and this is particularly true for ergonomics. The newly developed crane operator cab was designed with permanent use as a workplace in mind: It offers crane operators more space and convenience as well as a greater view of the working environment.

In crane operation, digital functions such as load antisway make work steps in the background more efficient and safer. These factors result in an increase in cargo-handling rates.

SMART CRANE FEATURES

More on pages 18 and 19

CONNECTIVITY

More on pages 20 and 21



For safety, ergonomics and productivity

Smart Crane Features

Konecranes Gottwald Mobile Harbor Cranes often work in confined spaces in conjunction with other port equipment when handling a wide variety of cargo. This results in multifaceted challenges in terms of safety, ergonomics and productivity. Our innovative smart crane features support numerous work steps.

These include:

- Automatic crane propping
- Reliable load control
- Automated execution of repetitive motions

We use the interaction of various smart technologies:

- Instruments, sensors and camera technology
- Control systems that provide information about handling processes
- Digital interconnectivity and bi-directional access to the cranes can be provided by our Service team if required

CONTAINER HANDLING

Konecranes is a leading provider of cargo-handling solutions for container terminals. In addition to high-performance equipment, innovative functions ensure a safe and smooth flow of goods and thus greater productivity.

CONTAINER FUNCTIONS

- Load antisway
- Lifting height and working radius limitations
- Landside lowering function

These features ensure:

- Easy steering and control of the spreader
- Safe working in combination with other equipment
- Avoidance of damage to infrastructure or other systems in the port or terminal and reduction of noise emissions

GENERAL CARGO HANDLING

The wide range of general cargo and the handling of heavy or bulky project cargo place different demands on mobile harbor cranes. We have developed many special smart crane features for these applications.

GENERAL CARGO FUNCTIONS

- Vertical lifting assistant
- XY control
- Tandem-lift assistant

These features ensure:

- Easy steering and control of heavy loads
- Easy guiding of loads, especially when using a remote control system
- Efficient handling of heavy loads with two cranes in tandem operation

BULK HANDLING

Konecranes Gottwald Mobile Harbor Cranes in the four-rope grab variant are designed for high-performance continuous operation in bulk handling. Smart crane features developed specifically for this application increase safety, ergonomics and productivity.

BULK HANDLING FUNCTIONS

- Self-learning grab filling level check
- Counter display for individual loading hatches
- Verifiable weighing system

These features ensure:

- High-speed handling performance due to best possible filling of the grab with each cycle
- Easy monitoring of the unloading schedule
- Efficient handling of high-value bulk cargo charged by weight

Everything always in view

Connectivity beyond the crane

Konecranes has been a pioneer in the digitalization of work processes for decades. Terminal operators have access to all crane data for the analysis of relevant parameters. On this basis, measures can be introduced to increase the performance yield. Service managers receive data feedback for their work area and can thus plan maintenance work in advance and minimize downtime. All our cranes are connected to the Konecranes Cloud Service.

VISUMATIC®

All parameters for crane operation are easily set using the VISUMATIC® crane management system, thanks to a user-friendly operator interface. In addition, the system provides clear access to all relevant crane data. Access for crane operators is via a touch screen in the tower cab and service technicians can access the system via a computer in the electrical room. Our numerous smart crane features are also set and controlled by this system.

yourKONECRANES

The yourKONECRANES web platform provides secure access to all data and other digital services for all Konecranes equipment. Customers can monitor and analyze their entire Konecranes fleet via one platform. Here customers will find offers, documentation and important documents on service and maintenance management. Data from our mobile harbor cranes are collected via TRUCONNECT® and are always available thanks to access via the Konecranes Cloud Service. The data are automatically updated as soon as the crane is online.

TELESERVICE

Ease of maintenance is an important factor for ensuring the reliability and availability of our Konecranes Gottwald Mobile Harbor Cranes. We therefore provide our experts with direct digital remote access to the cranes via our Teleservice. In this way, they support customers in troubleshooting, setting parameters and updating software without necessarily being on site – fast, simple, digital for minimized crane downtime.

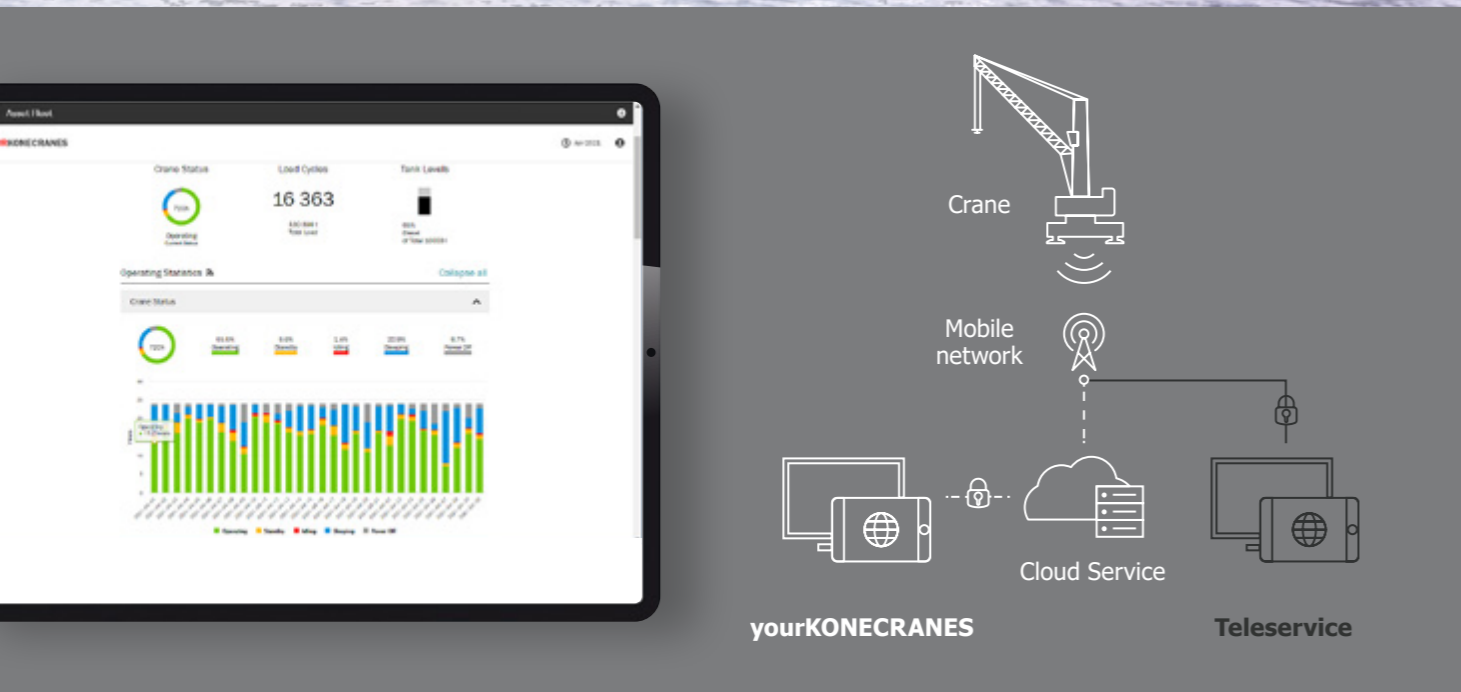

P for Powerful

The robustness and reliability of our cranes have always enabled high handling rates. In Generation 6, the renowned high working speeds go hand in hand with more powerful lifting capacity curves and twice the product lifecycle for many applications. In this way, we increase performance, durability and availability.

When it comes to ease of maintenance, we think ahead with a standardized design principle and engineered with standardized or identical assemblies across the entire model range. We ensure easy access to individual components as well as their availability and, as a result, we improve planning for maintenance, repair and spare parts management.

AVAILABILITY

In complex working environments, high availability is a crucial driver of success. Our new crane generation is designed for permanent high performance operation and ease of maintenance. In addition to easy access to all components, intelligent functions ensure better planning of maintenance and service work.

COST-EFFECTIVENESS

Profit from performance: Our cranes are designed for long operating times and maximum performance in cargo handling. At the same time, they stand for low consumption and wear as well as high efficiency. In addition, the versatility in handling all types of cargo and the high availability of our mobile harbor cranes enable terminal operators to work extremely cost effectively.

HOLISTIC

The new Konecranes Gottwald Mobile Harbor Cranes combine high performance with eco-efficiency, safety and ease of operation. To ensure that this interaction leads to sustainable success, we develop integrated, customer-oriented solutions for efficient use in ports and terminals.

RELIABLE ALL-ROUNDERS

More on pages 24 and 25

EASE OF MAINTENANCE

More on pages 26 and 27

High-performance handling of all types of cargo

Reliable all-rounders

Konecranes Gottwald Mobile Harbor Cranes combine high-performance handling with versatility in terminals all over the world. A worthwhile investment in the future: one crane, ideal for the current application and extremely flexible in terms of future requirements. The advance order program, which has been proven over decades, offers terminal operators quickly available cargo-handling solutions. Our cranes are ideally suited

both as special equipment and as all-rounders for handling all types of cargo. This is because of a modular hoist system that can be configured specifically for the application with regard to required lifting capacities and working speeds – combined with our modular drive system for supplying the required power. With Generation 6, we offer high-performance models for reliable use over a long period.

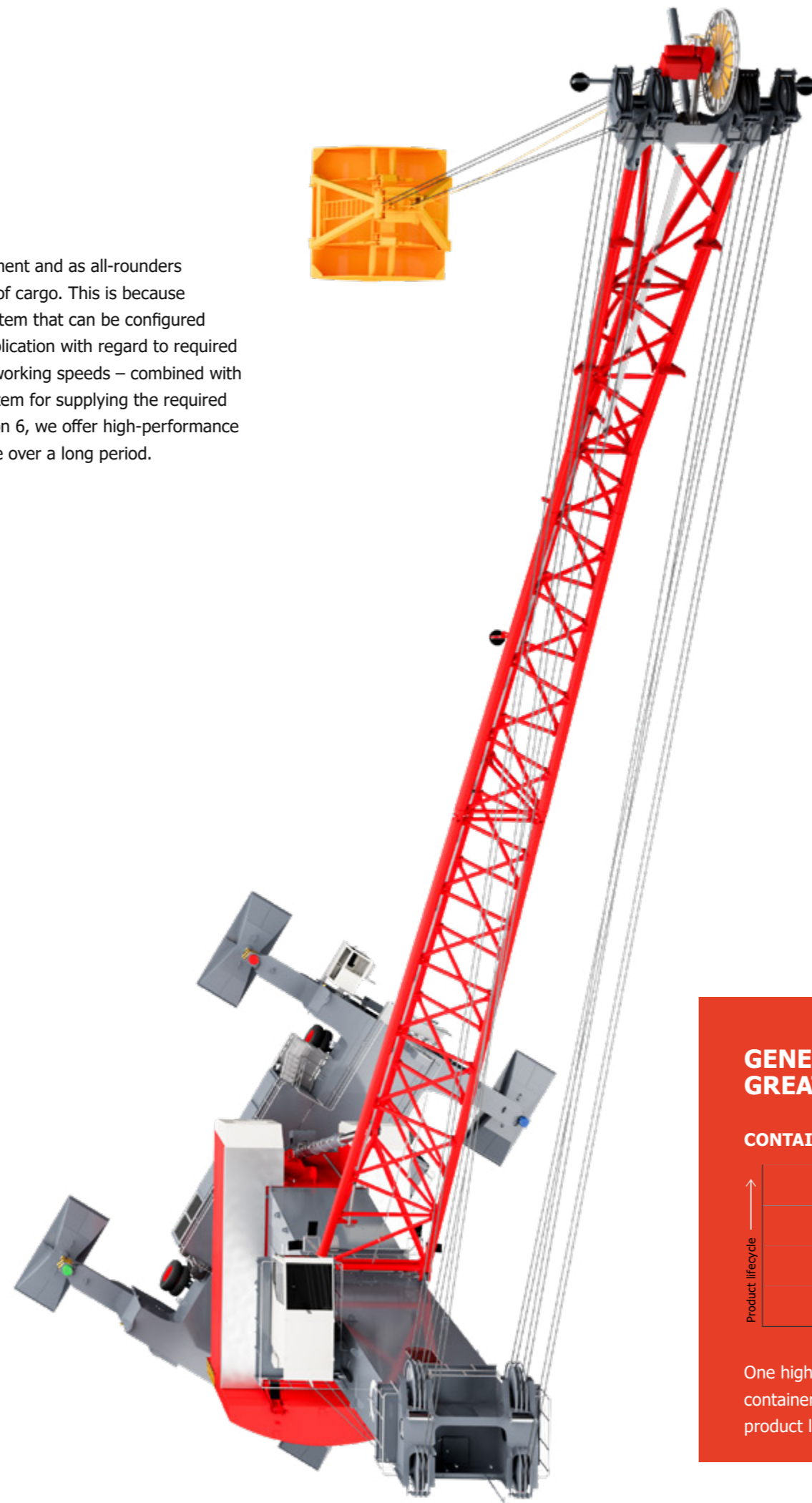

PROJECT CARGO HANDLING

The maximum lifting capacity of 200 t (or up to 400 t in tandem operation) makes our mobile harbor cranes ideal for precise and safe handling of heavy project cargo, such as mechanical parts or generators. Thanks to their 360° working range and powerful lifting capacity curves, they are suitable for bulky cargo such as wind turbine components.

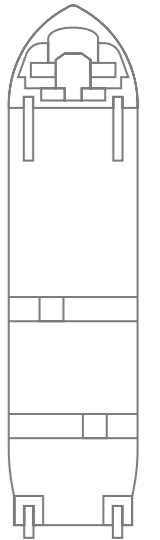
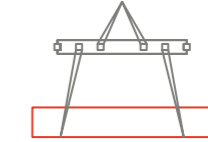

BULK HANDLING

Our robust four-rope grab cranes are impressive in the continuous-duty handling of bulk materials of all kinds, including scrap. They offer an up to 74 t curve for mechanical grabs, high classifications for long product lifecycle and, depending on the crane size, a handling capacity of up to 2,000 t/h. All of our crane models can be equipped with motor grabs, thus proving their versatility.

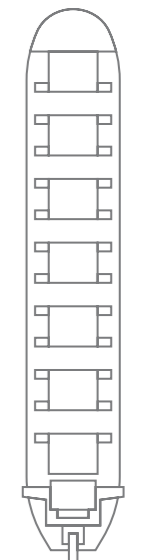

CONTAINER HANDLING

In container terminals, Konecranes Gottwald Mobile Harbor Cranes achieve a high throughput. They can be used to serve all sizes of vessels, including the super post-Panamax class with up to 22 container rows, in single or twin-lifts, and usually in combination with other Konecranes equipment such as reach stackers or straddle carriers.

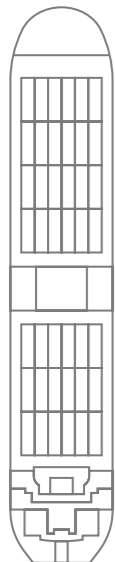
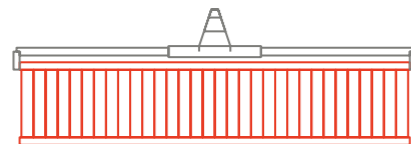

GENERAL CARGO HANDLING

Precision and speed are crucial factors in the handling of general cargo. A wide range of lifting accessories on the hook of Generation 6 mobile harbor cranes enables the movement of palletized goods, boxes and steel products. Our all-rounders also impress with powerful lifting capacity curves and high working speeds.

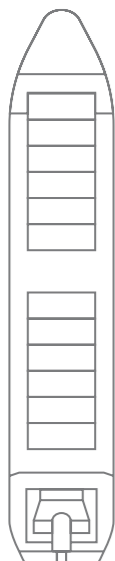
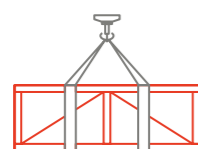

GENERATION 6 CRANES: GREATER PERFORMANCE

CONTAINER HANDLING

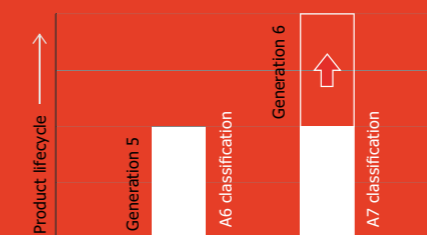

One higher-level classification for container handling doubles the crane's product lifecycle

BULK HANDLING

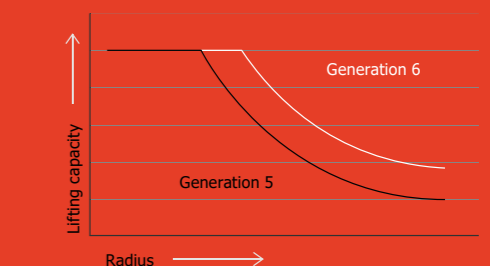

Four-rope grab lifting capacity curves with greater reach to serve bulk carrier hatches

Everything easily accessible

High ease of maintenance

Konecranes Gottwald Mobile Harbor Cranes are designed for high performance throughout their product lifecycle. This is supported, on the one hand, by the robust design, and, on the other hand, by the ample space available for service and maintenance work.

SAFE AND SECURED ACCESS FOR CRANE OPERATORS AND SERVICE TECHNICIANS

The 360° access to the crane sets new standards in safety for crane operators and service technicians. All access points to the tower via the chassis and the superstructure are secured with railings throughout. Ascent and descent are possible in any position of superstructure – safely and comfortably.

EASY TO MAINTAIN DOWN TO THE LAST DETAIL

Regular maintenance and timely replacement of wear and tear parts extend the product lifecycle of mobile harbor cranes and avoid unplanned downtime. The crane is always designed so that all maintenance and service points are safe and easy to reach, for example maintenance platforms on the tower head easily allow work to be performed the rope pulleys from all sides. For major service work, the diesel-generator set containers on the chassis can be easily dismantled and transported by forklift truck. The digital crane data in the yourKONECRANES portal enable forward planning of service work.



Konecranes Port Solutions

A reliable partner

Konecranes Gottwald Mobile Harbor Cranes are developed, designed and manufactured at the Competence Center in Düsseldorf. All experts work closely together and continuously improve technology and quality. Our proximity to the River Rhine enables us to ship quickly all over the world. Depending on their situation, customers can choose whether the crane is assembled at their terminal or delivered ready-assembled. Assembly and commissioning are always carried out by our trained staff and, if desired, with the involvement of the customer so that they can familiarize themselves with their new crane right from the start.

The broad product portfolio enables use in all port terminals. Our complementary Konecranes Port Services offer the right solution for every requirement, from spare parts to service and modernization measures through training for service technicians and crane operators.

PART OF THE KONECRANES NETWORK

Development, product design, manufacturing: Throughout the entire process, as part of Konecranes Port Solutions, we leverage the expertise of a global player in the port business. With our innovative ideas as a mobile harbor crane pioneer, this results in synergies that now allow our Generation 6 to be experienced in all its versatility.

HIGH PLANNING RELIABILITY AND FLEXIBILITY

The short delivery lead-time for our mobile harbor cranes enables our customers to plan with a high degree of reliability and flexibility. The versatility of our all-rounders pays off: Terminal operators always remain flexible in terms of the type of cargo they can handle. In addition, our mobile harbor cranes command a high resale value: Thanks to their long product lifecycle, they can still be used as reliable and efficient used cranes even after many years of continuous-duty operation.

FIND AND CONFIGURE THE RIGHT MODEL

Konecranes Gottwald Mobile Harbor Cranes offer a high degree of individual configuration possibilities. With our virtual product advisor, you can quickly find the right model for your requirements by selecting simple parameters.

Working together with you, our sales experts then configure your preselection right down to every relevant detail.



Click here to go to our mobile harbor crane product advisor.



Konecranes is a world-leading group of Lifting Businesses™, serving a broad range of customers, including manufacturing and process industries, shipyards, ports and terminals. Konecranes provides productivity enhancing lifting solutions as well as services for lifting equipment of all makes. In 2020, Group sales totaled EUR 3.2 billion. The Group has around 16,600 employees in 50 countries. Konecranes shares are listed on the Nasdaq Helsinki (symbol: KCR).

© 2021 Konecranes. All rights reserved. 'Konecranes', 'Lifting Businesses' and  are either registered trademarks or trademarks of Konecranes.

This publication is for general informational purposes only. Konecranes reserves the right at any time, without notice, to alter or discontinue the products and/or specifications referenced herein. This publication creates no warranty on the part of Konecranes, express or implied, including but not limited to any implied warranty or merchantability or fitness for a particular purpose.

